

# DX Slotted Angle

The versatile construction system

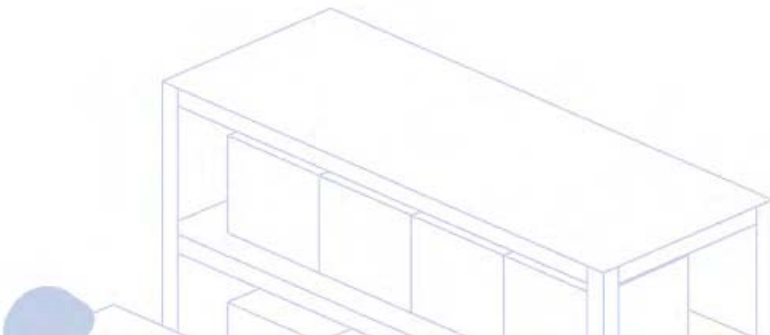

## Product overview

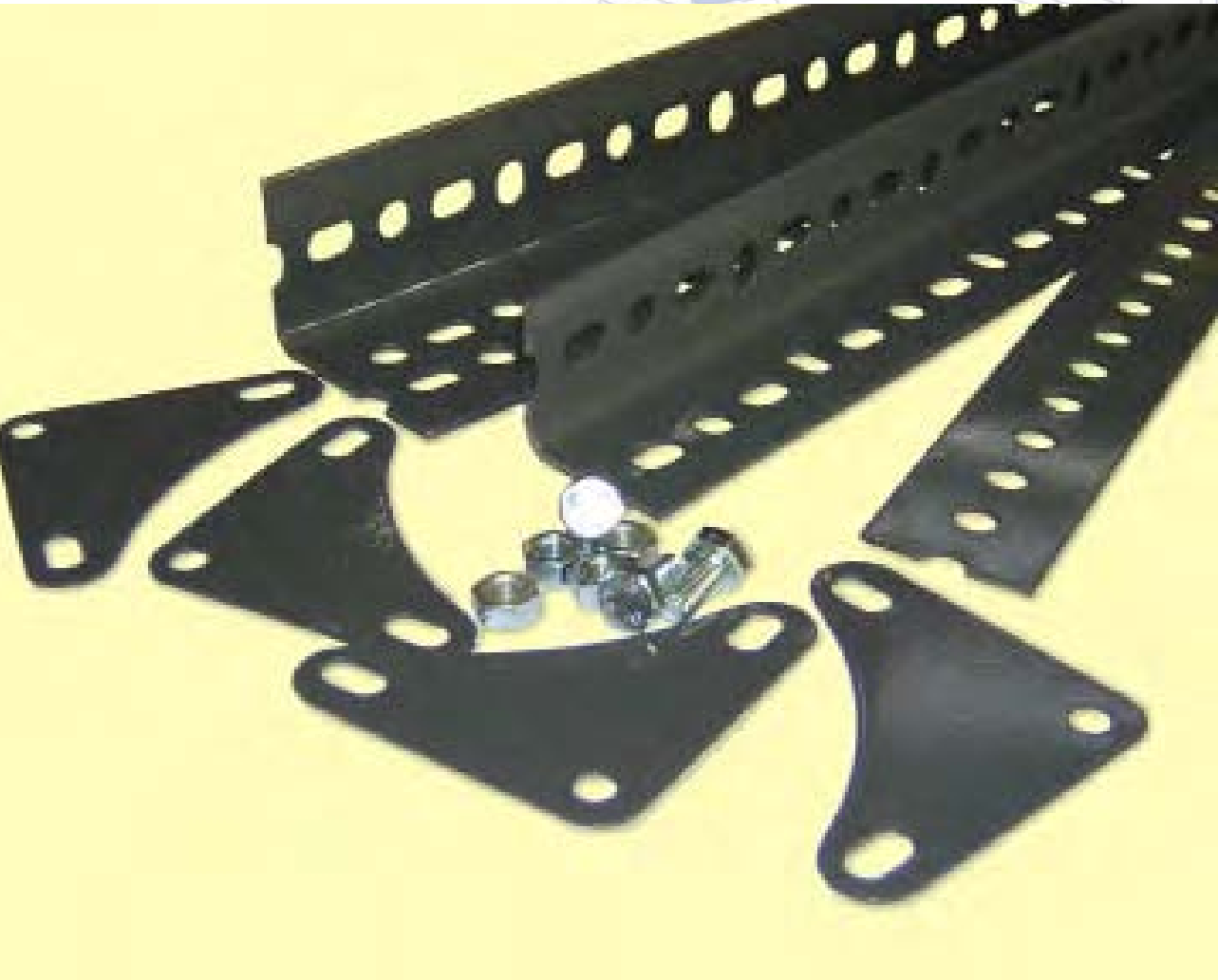

**Storax DX ('Dexion') Slotted Angle** launched the modern storage products industry over 50 years ago, and is still just as popular today!

Storax DX Slotted Angle is easy to use, strong and versatile, and is quickly and easily cut to size and bolted together to form frameworks which can be readily modified, dismantled and re-used over and over again.

This multi-purpose construction system lets you custom build shelving, benches, trollies, partitioning, fire barriers, and 100's of other applications, all without the need for welding, drilling or painting – the only limitation is your imagination!

The unique range of slot patterns used throughout the **Storax DX** range of punched strap, angle and channel means that all sections can be used together in the same installation.

As well as offering the perfect construction solution for new projects, **Storax DX** components are also fully interchangeable with the original Dexion® Slotted Angle system, and as such can integrate seamlessly to extend or adapt existing installations.



Details that count

## Punched Strap

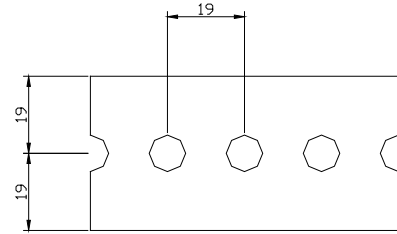
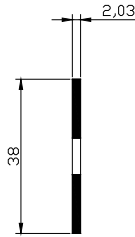

## DX160 Slotted Angle

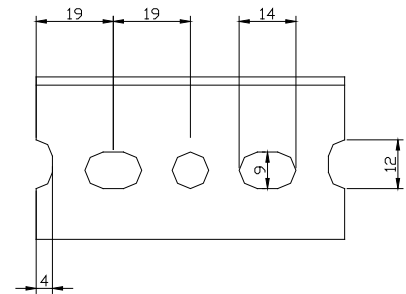
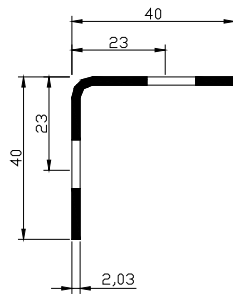

## DX260 Slotted Angle

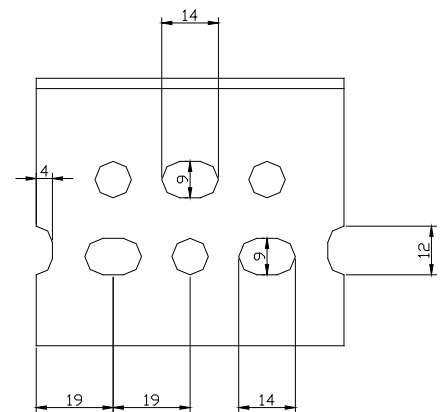
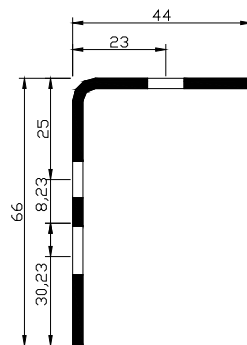

## DX345 Channel

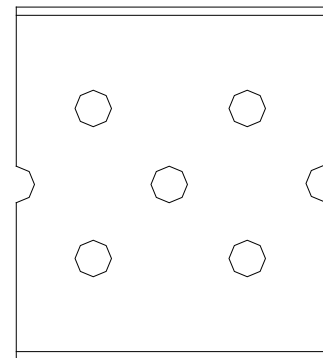
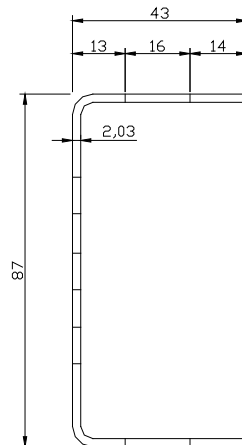

## Experience in store

A subsidiary of F Ramada of Portugal, Storax Racking Supplies was formed in 2003 to supply a wide range of Ramada products, solely through trade outlets in the UK and elsewhere in Europe.

The founding members of Storax Racking Supplies are all ex-employees of Dexion Ltd. Collectively we offer more than 120 years' experience of the industrial storage sector. Having worked in different areas of the business, our varied knowledge and experience enable our team to provide accurate product information, technical design advice, a prompt and efficient order-processing service and reliable customer support from the quotation stage to completion of every order. Our warehouse staff pride themselves on their excellent record for accurate picking and clear, careful packing.

Working out of our Hertfordshire office and warehouse north of London, we continuously adapt our product offering and services to respond to the changing needs of our customers. We can offer a wide range of racking, shelving and associated accessories from stock, and a made-to-order service from the factory in Portugal for non-standard sizes and colours.



## Range of products available... and more



SP80 Racking



Dynamic Racking



Drive-in Racking

Storax SP80 can be used in its own right to provide tailor-made racking solutions, and can also provide a framework for other methods of pallet storage, including Push Back Rack, Glidestock and Mobile Storage Systems.

Storax Cantilever racking is the ideal product when long lengths need to be stored.

Storax IM50 shelving is one of Europe's favourite bolt-free hand-loaded shelving systems. A range of accessories adds to this popular product's versatility and makes it a logical choice for many industrial and semi-commercial applications.

Storax Slotted Angles are still faithful to the original Dexion designs and, used in conjunction with the normal range of accessories, remain as flexible in their applications today as they have always been.



Cantilever Racking



IM50 Shelving



Slotted Angle